



NOTES:

1. SYMBOL  INDICATES MOUNTING POINT, 3/8-16 THREADED HOLE (PI ANGLE).
2. SYMBOL  INDICATES MOUNTING POINT, 3/8-16 THREADED HOLE (NUT PLATE).
3. SYMBOL  INDICATES CENTER OF BALANCE.
4. WEIGHT APPROX. 165 LBS.
5. SHIPPING WEIGHT APPROX. 180 LBS.

REV	DESCRIPTION	APVD/DATE
0	UPGRADE TO PRODUCTION PER DSR 01-435 MFL 5/10/01	MFL 5/11/01

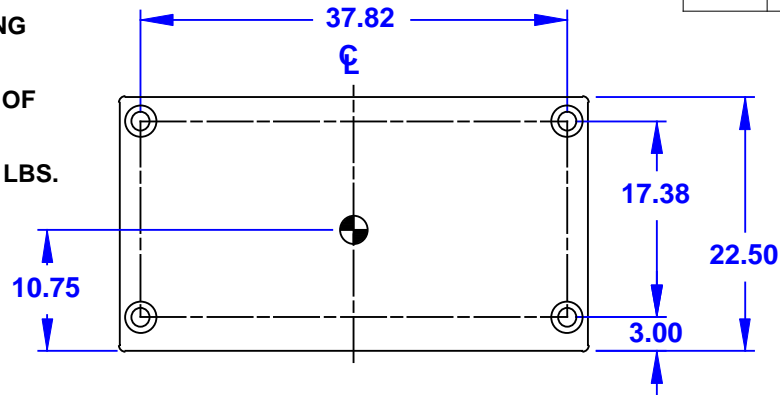

TOP/BOTTOM

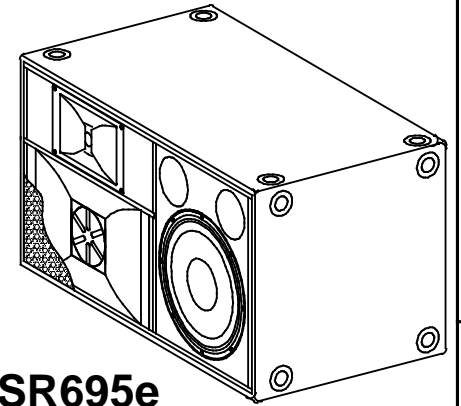

ASR695e

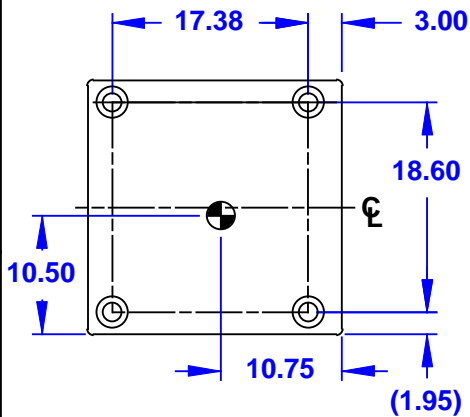

**LEFT SIDE
DIMENSIONS APPLY
TO BOTH SIDES**

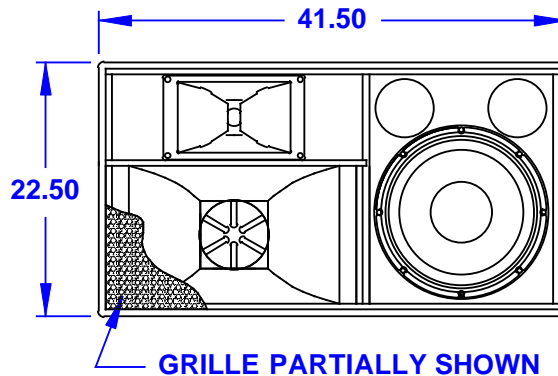

GRILLE PARTIALLY SHOWN

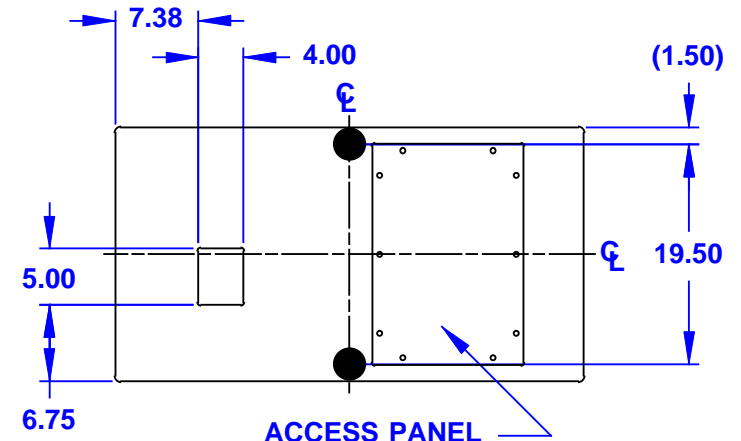

FRONT



ACCESS PANEL

BACK

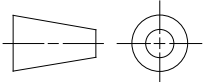
DOCUMENT CONTROL PER SPECIFICATION 4.5.201

 THIRD ANGLE PROJECTION	UNLESS OTHERWISE SPECIFIED: ALL DIMENSIONS ARE IN INCHES TOLERANCE IN INCHES .XX ± .13 ANGLES ±1° (X.XX) = REF DIMS NO TOLERANCE IMPLIED T.S.C.=THEORETICAL SHARP CORNER DIMENSIONS ACROSS CENTERLINES TO BE SYMMETRICAL	STATUS: PRODUCTION		 EASTERN ACOUSTIC WORKS ONE MAIN STREET WHITINSVILLE, MA 01588 USA	
		APPROVALS	DATE		TITLE: CABINET/FINISHED/BLACK/ ASR695e [MECHANICAL SPECIFICATION]
THIS DRAWING IS THE PROPERTY OF EAW AND SHALL NOT BE COPIED, REPRODUCED, OR USED AS THE BASIS FOR MANUFACTURE OR SALE OF APPARATUS WITHOUT WRITTEN AUTHORIZATION. DO NOT SCALE DRAWING.		DRAWN: RAS	2/14/01	SHEET 1 OF 1	SCALE: 1 TO 14
		CHECKED: MFL	5/11/01	DRAWING NUMBER: 509134	REVISION: 0
		DES ENG: NB	5/14/01		
		MFG ENG: DBD	5/18/01		